

# GATE question papers: Chemical Engineering 2007 (CH)

Q. 1 – Q – 20 carry one mark each

- Give  $i = \sqrt{-1}$ , the ratio  $\frac{(i+3)}{(i+1)}$  is given by  
 (A)  $i$  (B)  $-2$  (C)  $-i+2$  (D)  $i+1$
- The value of "a" for which the following set of equations  

$$\begin{aligned} y + 2z &= 0 \\ 2x + y + z &= 0 \\ ax + 2y &= 0 \end{aligned}$$
 have non-trivial solution, is  
 (A) 0 (B) 8 (C) -2 (D) 3
- The initial condition for which the following equation  
 $(x^2 + 2x) \frac{dy}{dx} = 2(x+1); y(x_0) = y_0$   
 has infinitely many solutions, is  
 (A)  $y(x=0) = 5$  (B)  $y(x=0) = 1$  (C)  $y(x=2) = 1$  (D)  $y(x=-2) = 0$
- Give that the Laplace transform of the function below over a single period  $0 < t < 2$  is  $\frac{1}{s^2}(1 - e^{-s})^2$ , the Laplace transform of the periodic function over  $0 < t < \infty$  is

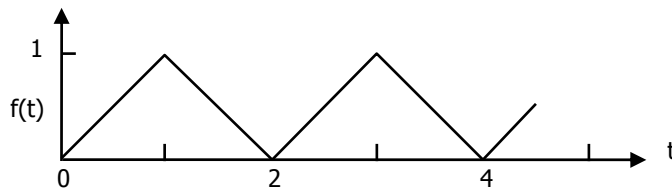

- (A)  $\frac{1}{s}(1 - e^{-s})^2$  (B)  $\frac{1}{s}(1 - e^{-s})^2$  (C)  $\frac{1}{s^2} \frac{(1 - e^{-1})}{(1 + e^{-s})}$  (D)  $\frac{1}{s} \tanh \frac{s}{2}$
- If  $T_A$  and  $T_B$  are the boiling points of pure A and pure B respectively and  $T_{AB}$  is that of a non-homogeneous immiscible mixture of A and B, then  
 (A)  $T_{AB} < T_A$  and  $T_B$  (B)  $T_{AB} > T_A$  and  $T_B$   
 (C)  $T_A > T_{AB} > T_B$  (D)  $T_B > T_{AB} > T_A$
  - The state of an ideal gas is changed from  $(T_1, P_1)$  to  $(T_2, P_2)$  in a constant volume process. To calculate the change in enthalpy,  $\Delta h$ , ALL of the following properties/variables are required.  
 (A)  $C_V, P_1, P_2$  (B)  $C_P, T_1, T_2$   
 (C)  $C_P, T_1, T_2, P_1, P_2$  (D)  $C_V, P_1, P_2, T_1, T_2$
  - The change in entropy of the system,  $\Delta S_{sys}$ , undergoing a cyclic irreversible process is  
 (A) greater than 0 (C) less than zero  
 (B) equal to zero (D) equal to the  $\Delta S_{surroundings}$
  - Parameters 'a' and 'b' in the van der Waals and other cubic equations of state represent  
 (A) a – molecular weight b – molecular polarity  
 (B) a – molecular size b – molecular attraction  
 (C) a – molecular size b – molecular speed  
 (D) a – molecular attraction b – molecular size

9. If  $m_i$ ,  $\bar{m}$ ,  $m_i^R$ ,  $m_i^E$  are molar, partial molar, residual and excess properties respectively for a pure species "i", the mixture property  $M$  of a binary non-ideal mixture of components 1 and 2, is given by  
 (A)  $x_1 \bar{m}_1 + x_2 \bar{m}_2$  (B)  $x_1 m_1^R + x_2 m_2^R$   
 (C)  $x_1 m_1 + x_2 m_2$  (D)  $x_1 m_2^E + x_2 m_2^E$
10. Consider a soap film bubble of diameter  $D$ . If the external pressure is  $P_o$  and the surface tension of the soap film is  $\sigma$ , the expression for the pressure inside the bubble is  
 (A)  $P_o$  (B)  $P_o + \frac{2\sigma}{D}$  (C)  $P_o + \frac{4\sigma}{D}$  (D)  $P_o + \frac{8\sigma}{D}$
11. In Tyler series, the ratio of the aperture size of a screen to that of the next smaller screen is  
 (A)  $1/\sqrt{2}$  (B)  $\sqrt{2}$  (C) 1.5 (D) 2
12. Size reduction of coarse hard solids using a crusher is accomplished by  
 (A) attrition (B) compression (C) cutting (D) impact
13. In constant pressure filtration, the rate of filtration follows the relation ( $v$ : filtrate volume,  $t$ : time,  $k$  and  $c$ : constants).  
 (A)  $\frac{dv}{dt} = kv + C$  (B)  $\frac{dv}{dt} = \frac{1}{kv + C}$  (C)  $\frac{dv}{dt} = kv$  (D)  $\frac{dv}{dt} = kv^2$
14. Sticky materials are transported by  
 (A) apron conveyor (B) screw conveyor  
 (C) belt conveyor (D) hydraulic conveyor
15. The Grashof Number is  
 (A) thermal diffusivity/mass diffusivity (B) inertial force/surface tension force  
 (C) sensible heat / latent heat (D) buoyancy force / viscous force
16. An operator was told to control the temperature of a reactor at 60°C. The operator set the set-point of the temperature controller at 60. The scale actually indicated 0 to 100% of a temperature range of 0 to 200°C. This caused a runaway reaction by over-pressurizing the vessel, which resulted in injury to the operator. The actual set-point temperature was  
 (A) 200°C (B) 60°C (C) 120°C (D) 100°C
17. Select the most appropriate pump from Group 2 to handle each fluid flow given in Group 1,  
**Group 1** **Group 2**  
 P. Highly viscous fluid flow (1) piston pump  
 Q. Fluid containing large amount of Abrasive solids (2) gear pump  
 (3) plunger pump  
 (4) centrifugal pump  
 (A) P-(2), Q-(1) (B) P-(2), Q-(4)  
 (C) P-(3), Q-(4) (D) P-(4), Q-(3)
18. A cylindrical storage tank can have a self-supported conical roof,  
 (A) if its diameter is less than 20 m  
 (B) if its diameter is more than 50 m  
 (C) if the thickness of the roof is more than that of the cylindrical shell  
 (D) whatever is the diameter
19. Which of the following is desirable in gasoline but undesirable in kerosene?  
 (A) Aromatics (B) Mercaptans  
 (C) Naphthenic Acid (D) Paraffins

20. In the Sulfite process for paper manufacture, the 'cooking liquor' is  
 (A) Magnesium bisulfite and sulfur dioxide in acid medium  
 (B) Magnesium sulfite and magnesium dicarbonate  
 (C) Sodium sulfite and magnesium sulfite  
 (D) Sodium sulfite, sodium bisulfite and sulfur dioxide.

**Q. 21 to 75 carry two marks each.**

21. If  $z = x + iy$  is a complex number, where  $i = \sqrt{-1}$  then the derivative of  $z\bar{z}$  at  $2 + i$  is  
 (A) 0 (B) 2 (C) 4 (D) does not exist

22.  $\underline{\underline{A}}$  and  $\underline{\underline{B}}$  are two  $3 \times 3$  matrix such that,  $\underline{\underline{A}} = \begin{bmatrix} -2 & 4 & 6 \\ 1 & 2 & 1 \\ 0 & 4 & 4 \end{bmatrix}$ ,  $\underline{\underline{B}} = \underline{\underline{0}}$  and  $\underline{\underline{A}}\underline{\underline{B}} = \underline{\underline{0}}$ . Then the rank of matrix  $\underline{\underline{B}}$  is  
 (A)  $r = 2$  (B)  $r < 3$  (C)  $r \leq 3$  (D)  $r = 3$

23. The solution of the following differential equation  $x \frac{dy}{dx} + y(x^2 - 1) = 2x^3$  is  
 (A) 0 (B)  $2 + ce^{\frac{x^2}{2}}$  (C)  $c_1x + c_2x^2$  (D)  $2 + cxe^{\frac{x^2}{2}}$

24. The directional derivative of  $f = \frac{1}{2}\sqrt{x^2 + y^2}$  at  $(1, 1)$  in the direction of  $\vec{b} = \vec{i} - \vec{j}$  is  
 (A) 0 (B)  $1/\sqrt{2}$  (C)  $\sqrt{2}$  (D) 2

25. Evaluate the following integral ( $n \neq 0$ )  

$$\int (-xy^n dx + x^n y dy)$$
 within the area of a triangle with vertices  $(0, 0)$ ,  $(1, 0)$  and  $(1, 1)$  (counter-clockwise)  
 (A) 0 (B)  $1/(n + 1)$  (C)  $1/2$  (D)  $n/2$

26. The family of curves that is orthogonal to  $xy = c$  is  
 (A)  $y = c_1x$  (B)  $y = c_1/x$  (C)  $y^2 + x^2 = c_1$  (D)  $y^2 - x^2 = c_1$

27. The Laplace transform of  $f(t) = \frac{1}{\sqrt{t}}$  is  
 (A)  $\sqrt{\frac{\pi}{s}}$  (B)  $\frac{1}{\sqrt{s}}$  (C)  $\frac{1}{s^{\frac{3}{2}}}$  (D) does not exist

28. The thickness of a conductive coating in micrometers has a probability density function of  $600x^{-2}$  for  $100 \mu\text{m} < x < 120 \mu\text{m}$ . The mean and the variance of the coating thickness is  
 (A)  $1 \mu\text{m}$ ,  $108.39 \mu\text{m}^2$  (B)  $33.83 \mu\text{m}$ ,  $1 \mu\text{m}^2$   
 (C)  $105 \mu\text{m}$ ,  $11 \mu\text{m}^2$  (D)  $109.39 \mu\text{m}$ ,  $33.83 \mu\text{m}^2$

29. If the percent humidity of air ( $30^\circ\text{C}$ , total pressure  $100 \text{ kPa}$ ) is  $24\%$  and the saturation pressure of water vapor at that temperature is  $4 \text{ kPa}$ , the percent relative humidity and the absolute humidity of air are  
 (A) 25.2, 0.0062 (B) 25, 0.0035 (C) 20.7, 0.0055 (D) 18.2, 0.00

30. For the two paths as shown in the figure, one reversible and one irreversible, to change the state of the system from a to b,

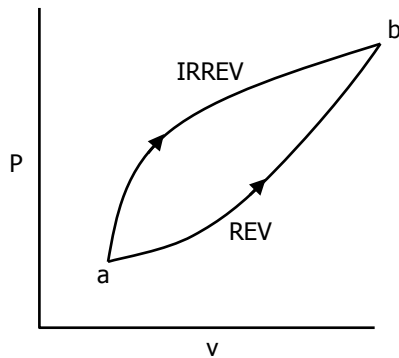

- (A)  $\Delta U, Q, W$  are same  
 (B)  $\Delta U$  is same  
 (C)  $Q, W$  are same  
 (D)  $\Delta U, Q$ , are different.
31. For a pure substance, the Maxwell's relation obtained from the fundamental property relation  $du = Tdz - Pd v$  is
- (A)  $(\partial T / \partial v)_s = -(\partial P / \partial s)_v$   
 (B)  $(\partial P / \partial T)_v = (\partial s / \partial v)_T$   
 (C)  $(\partial T / \partial P)_s = (\partial v / \partial s)_p$   
 (D)  $(\partial v / \partial T)_p = -(\partial s / \partial P)_T$ .
32. Which of the following represents the Carnot cycle (ideal engine)?

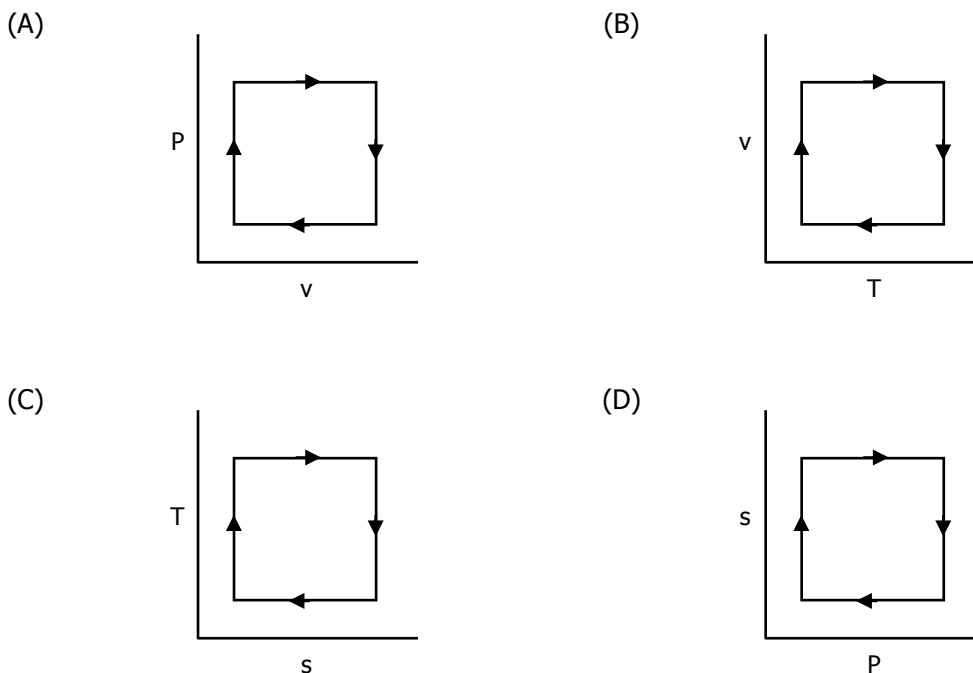

33. 2 kg of steam in a piston-cylinder device at 400 kPa and 175 °C undergoes a mechanically reversible, isothermal compression to a final pressure such that the steam becomes just saturated. What is the work,  $W$ , required for the process.

Data:

$T = 175^\circ\text{C}, P = 400 \text{ kPa} - v = 0.503 \text{ m}^3/\text{kg}, u = 2606 \text{ kJ/kg}, s = 7.055 \text{ kJ/kg-K}$

$T = 175^\circ\text{C}, \text{satd. vapor} - v = 0.216 \text{ m}^3/\text{kg}, u = 2579 \text{ kJ/kg}, s = 6.622 \text{ kJ/kg-K}$

- (A) 0 kJ      (B) 230 kJ      (C) 334 kJ      (D) 388 kJ

34. Vapor phase hydration of  $C_2H_4$  to ethanol by the following reaction

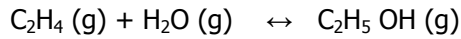

attains equilibrium at 400 K and 3 bar. The standard Gibbs free energy change of reaction at these conditions is  $\Delta G^\circ = 4000 \text{ J/mol}$ . For 2 moles of an equimolar feed of ethylene and steam, the equation in terms of the extent of reaction  $\varepsilon$  (in mols) at equilibrium is

- (A)  $\frac{\varepsilon(2-\varepsilon)}{(1-\varepsilon)^2} - 0.3 = 0$       (B)  $\frac{(2-\varepsilon)^2}{\varepsilon(2-\varepsilon)} - 0.9 = 0$   
 (C)  $\frac{\varepsilon}{(1-\varepsilon)^2} - 0.3 = 0$       (D)  $\frac{\varepsilon(2-\varepsilon)}{(1-\varepsilon)^2} - 0.9 = 0$

35. A pipeline system carries crude oil of density  $800 \text{ kg/m}^3$ . The volumetric flow rate at point 1 is  $0.28 \text{ m}^3/\text{s}$ . The cross sectional areas of the branches 1, 2 and 3 are  $0.012$ ,  $0.008$  and  $0.004 \text{ m}^2$  respectively. All the three branches are in a horizontal plane and the friction is negligible. If the pressures at the points 1 and 3 are  $270 \text{ kPa}$  and  $240 \text{ kPa}$  respectively, then the pressure at point 2 is

- (A) 202 kPa  
 (B) 240 kPa  
 (C) 284 kPa  
 (D) 355 kPa

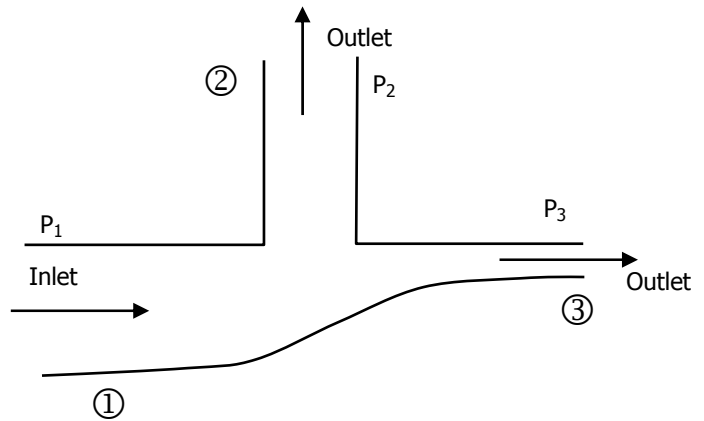

36. The figure shows the idealized view of a return elbow or U bend, which is connected to two pipes by flexible hoses that transmit no force. Water with density  $1000 \text{ kg/m}^3$  flows at velocity of  $10 \text{ m/s}$  through the pipe, which has a uniform ID of  $0.1\text{m}$ . The gauge pressure at points 1 and 2 are  $304 \text{ kPa}$  and  $253 \text{ kPa}$  respectively. The horizontal force  $F$  required to keep the elbow in position is

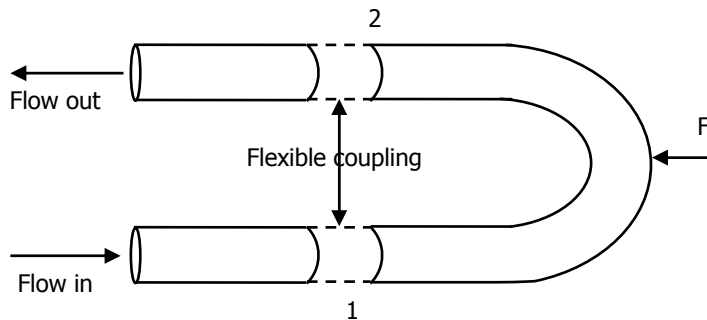

- (A) 1574 N      (B) 1970 N      (C) 5942 N      (D) 7533 N

37. A tube of diameter  $D$  and length  $L$  is initially filled with a liquid of density  $\rho$  and viscosity  $\mu$ . It is then pushed out by the application of a constant force  $F$  to the plunger as shown in the figure. Assuming laminar flow and pseudo steady state, the time required to expel one half of the liquid out of the tube is

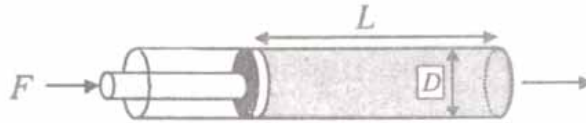

- (A)  $\frac{3\pi\mu L^2}{F}$       (B)  $\frac{3\pi\mu D^2}{F}$       (C)  $\frac{6\pi\mu L^2}{F}$       (D)  $\frac{6\pi\mu DL^2}{F}$

38. The figure shows a series-parallel configuration of three identical centrifugal pumps. The head increase  $\Delta H$  across a single such pump varies with flowrate  $Q$  according to  $\Delta H = a - bQ^2$ . The expression for the total head increase  $\Delta H = H_2 - H_1$  in terms of  $a$  and  $b$  and the total flowrate  $Q_1$  for this configuration is given by

- (A)  $2a - \frac{5}{4}bQ_1^2$   
 (B)  $2a - bQ_1^2$   
 (C)  $2a - 2bQ_1^2$   
 (D)  $a - bQ_1^2$

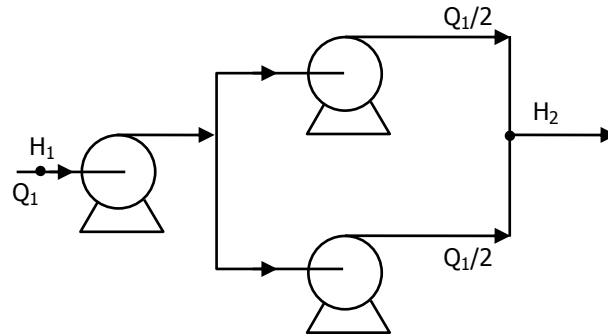

39. The pressure differential across a venturimeter, inclined at  $45^\circ$  to the vertical (as shown in the figure) is measured with the help of a manometer to estimate the flowrate of a fluid flowing through it. If the density of the flowing fluid is  $\rho$  and the density of the manometer fluid is  $\rho_m$ , the velocity of the fluid at the throat can be obtained from the expression

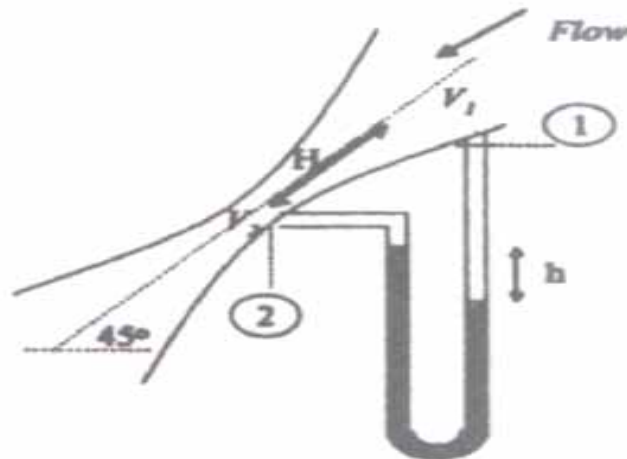

- (A)  $\frac{V_2^2 - V_1^2}{2g} = \frac{h(P_m - P)}{P} + H \sin 45^\circ$       (B)  $\frac{V_2^2 - V_1^2}{2g} = \frac{hP_m}{P} + H \sin 45^\circ$   
 (C)  $\frac{V_2^2 - V_1^2}{2g} = \frac{hP_m}{P}$       (D)  $\frac{V_2^2 - V_1^2}{2g} = \frac{h(P_m - P)}{P}$

40. In the Stokes regime, the terminal velocity of particles for centrifugal sedimentation is given by

$$U_t = \omega^2 r (\rho_p - \rho) d_p^2 / 18 \mu$$

where,  $\omega$ : angular velocity;  $r$ : distance of the particle from the axis of rotation;

$\rho_p$ : density of the particle;  $\rho$ : density of the fluid;  $d_p$ : diameter of the particle and  $\mu$ : viscosity of the fluid.

In a Bowl centrifugal classifier operating at 60 rpm with water ( $\mu = 0.001 \text{ kg/m.s}$ ), the time taken for a particle ( $d_p = 0.0001 \text{ m}$ , sp.gr = 2.5) in seconds to traverse a distance of 0.05 m from the liquid surface is

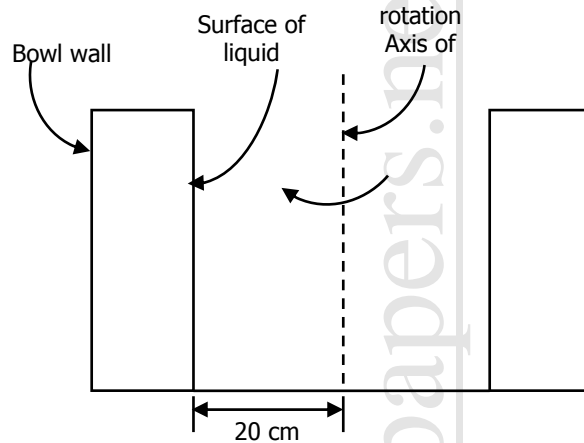

- (A) 4.8                      (B) 5.8                      (C) 6.8                      (D) 7.8

41. For the two long concentric cylinders with surface areas  $A_1$  and  $A_2$ , the view factor  $F_{22}$  is given by

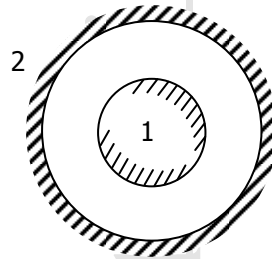

- (A) 0                      (B) 1                      (C)  $1 - A_1/A_2$                       (D)  $A_1/A_2$

42. The composite wall of an oven consists of three materials A, B and C. Under steady state operating conditions, the outer surface temperature  $T_{s,o}$  is 20 °C, the inner surface temperature  $T_{s,i}$  is 600 °C and the oven air temperature is  $T_\infty = 800$  °C. For the following data thermal conductivities  $k_A = 20 \text{ W/(m K)}$  and  $k_C = 50 \text{ W/m K}$ , thickness  $L_A = 0.3 \text{ m}$ ,  $L_B = 0.15 \text{ m}$  and  $L_C = 0.15 \text{ m}$ , inner-wall heat transfer coefficient  $h = 25 \text{ W/m}^2 \text{ K}$ , the thermal conductivity  $k_B \text{ W/(mK)}$  of the material B, is calculated as

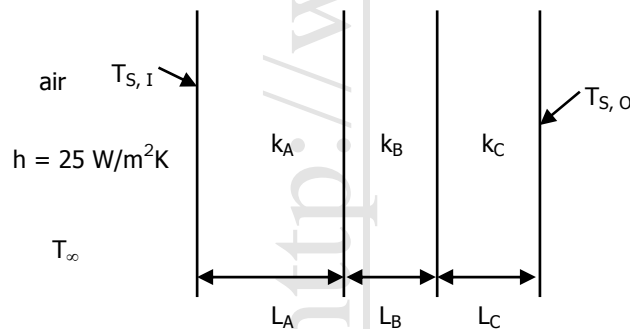

- (A) 35                      (B) 1.53                      (C) 0.66                      (D) 0.03

43. Water enters a thin walled tube ( $L = 1 \text{ m}$ ,  $D = 3 \text{ mm}$ ) at an inlet temperature of  $97^\circ\text{C}$  and mass flow rate  $0.015 \text{ kg/s}$ . The tube wall is maintained at a constant temperature of  $27^\circ\text{C}$ . Given the following data for water.

Density,  $\rho = 1000 \text{ kg/m}^3$   
 Viscosity,  $\mu = 489 \cdot 10^{-6} \text{ Ns/m}^2$   
 Specific heat  $C_p = 4184 \text{ J/kg/k}$   
 Inside heat transfer coefficient  $h = 12978 \text{ W/ (m}^2 \text{ K)}$ ,  
 The outlet temperature of water in  $^\circ\text{C}$  is,

- (A) 28                      (B) 37                      (C) 62                      (D) 96

44. A hot fluid entering a well-stirred vessel is cooled by feeding cold water through a jacket around the vessel. Assume the jacket is well-mixed. For the following data,

mass flowrates of the hot fluid =  $0.25 \text{ kg/s}$

mass flow rate of cold water =  $0.4 \text{ kg/s}$

specific heats of oil =  $6000 \text{ J/kgK}$

specific heat of cold water =  $4184 \text{ J/kgK}$

the inlet and exit temperature of the hot fluid is  $150^\circ\text{C}$  and  $100^\circ\text{C}$  respectively.

inlet temperature of cold water =  $20^\circ\text{C}$

the overall hat transfer coefficient is  $500 \text{ W/m}^2\text{K}$ .

the heat transfer area in  $\text{m}^2$ , is

- (A) 1.82                      (B) 2.1                      (C) 3                      (D) 4.26

45. Consider a liquid stored in a container exposed to its saturated vapor at constant temperature  $T_{\text{sat}}$ . The bottom surface of the container is maintained at a constant temperature  $T_s < T_{\text{sat}}$  while its side walls are insulated. The thermal conductivity  $k_l$  of the liquid, its latent heat of vapourisation  $\lambda$  and density  $\rho_l$  are known. Assuming a linear temperature distribution in the liquid, the expression for the growth of the liquid layer  $\delta$  as a function of time  $t$  is given by

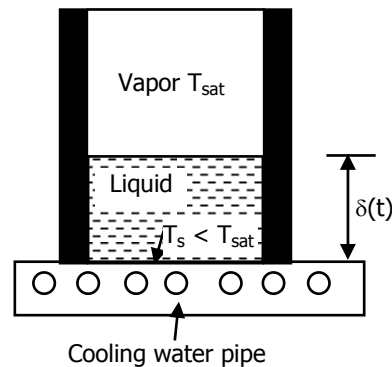

- (A)  $\delta(t) = \left[ \frac{4K_t(T_{\text{sat}} - T_s)}{\rho_l \lambda} t \right]^{1/2}$                       (B)  $\delta(t) = \left[ \frac{K_t(T_{\text{sat}} - T_s)}{\rho_l \lambda} t \right]^{1/2}$
- (C)  $\delta(t) = \left[ \frac{2K_t(T_{\text{sat}} - T_s)}{\rho_l \lambda} t \right]^{1/2}$                       (D)  $\delta(t) = \left[ \frac{K_t(T_{\text{sat}} - T_s)}{\rho_l \lambda} t \right]^{1/2}$



46. The following list of options P, Q, R and S are some of the important considerations in the design of a shell and tube heat exchanger.
- (P) square pitch permits the use of more tubes in a given shell diameter
  - (Q) the tube side clearance should not be less than one fourth of the tube diameter
  - (R) baffle spacing is not greater than the diameter of the shell or less than one-fifth of the shell diameter
  - (S) The pressure drop on the tube side is less than 10 psi.
- Pick out the correct combination of 'TRUE' statements from the following:
- (A) P, Q and R
  - (B) Q, R and S
  - (C) R, S and P
  - (D) P, Q, S and S

47. The following figure depicts steady one-dimensional diffusion of water vapour from the surface of water taken in a conical flask at room temperature. Derive the governing equation for determining the concentration profile of water vapour in the gas medium. Neglect change of level of water due to condensation. The temperatures of the gas and the liquid media are identical and constant.

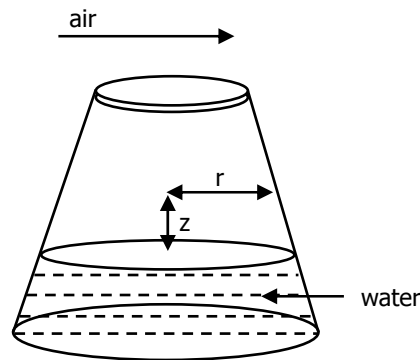

(A)  $\frac{d}{dz} \left[ r^2 \frac{CD_{WA}}{1-x_w} \frac{dx_w}{dz} \right] = 0$       (B)  $\frac{d}{dz} \left[ \frac{CD_{WA}}{1-x_w} \frac{dx_w}{dz} \right] = 0$

(C)  $\frac{d}{dz} \left[ r \frac{CD_{WA}}{1-x_w} \frac{dx_w}{dz} \right] = 0$       (D)  $\frac{d}{dz} \left[ rCD_{WA} \frac{dx_w}{dz} \right] = 0$

48. In a distillation operation, it is desired to have a very high purity bottom product. Initially, a kettle-type reboiler is used at the bottom of the column and the following analytical equation is used to obtain the equilibrium trays in the exhausting section of the column

$$N_p - m + 1 = \frac{\log \left[ \frac{x_m - x_w / \alpha (1 - \bar{A}) + \bar{A}}{x_w - x_w / \alpha} \right]}{\log(\bar{A})}$$

where  $x_m$  is the composition of the liquid leaving tray  $m$ . Tray  $m$  is the last equilibrium tray obtained by a McCabe Thiele graph of the exhausting section. If the kettle-type reboiler is replaced by a thermo-syphon reboiler, the analytical equation, for the exhausting section will be

(A)  $N_p - m + 1 = \frac{\log \left[ \frac{x_m - x_w / \alpha (1 - \bar{A}) + \bar{A}}{x_w - x_w / \alpha} \right]}{\log(\bar{A})}$       (B)  $N_p + 1 = \frac{\log \left[ \frac{x_m - x_w / \alpha (1 - \bar{A}) + \bar{A}}{x_w - x_w / \alpha} \right]}{\log(\bar{A})}$

(C)  $N_p - m = \frac{\log \left[ \frac{x_m - x_w / \alpha (1 - \bar{A}) + \bar{A}}{x_w - x_w / \alpha} \right]}{\log(\bar{A})}$       (D)  $N_p - m + 2 = \frac{\log \left[ \frac{x_m - x_w / \alpha (1 - \bar{A}) + \bar{A}}{x_w - x_w / \alpha} \right]}{\log(\bar{A})}$

49. A 50 cm X 50 cm X 1 cm flat wet sheet weighing 2 kg initially was dried from both the sides under constant drying rate period. It took 1000 secs for the weight of the sheet to reduce to 1.75 kg. Another 1m X 1m X 1cm flat sheet is to be dried from one side only. Under the same drying rate and other conditions, time required for drying (in secs) from initial weight of 4 kg to 3 kg is  
 (A) 1000 (B) 1500 (C) 2000 (D) 2500
50. It is desired to reduce the concentration of pyridine in 500 kg of aqueous solution from 20 weight percent to 5 wt percent in a single batch extraction using chloro- benzene as solvent. Equilibrium compositions (end points of the tie line) in terms of weight percent of pyridine-water-chlorobenzene are (5, 95, 0) and (11, 0, 89).  
 The amount of pure solvent required in kg for the operation is  
 (A) 607 (B) 639 (C) 931 (D) 1501
51. Benzene in an air-benzene mixture is to be reduced from 5.2 mol% in the feed to 0.5 mol% by contacting with wash oil in a multistage countercurrent gas absorber. The inlet flowrate of air-benzene mixture is 10 mol/s while benzene free wash oil comes in at 9.5 mol/s. If the equilibrium curve is given as  $Y^* = X$ , where  $Y^*$  and  $X$  are equilibrium mole ratios of benzene in air and benzene in oil, the number of equilibrium stages required to achieve the above separation is

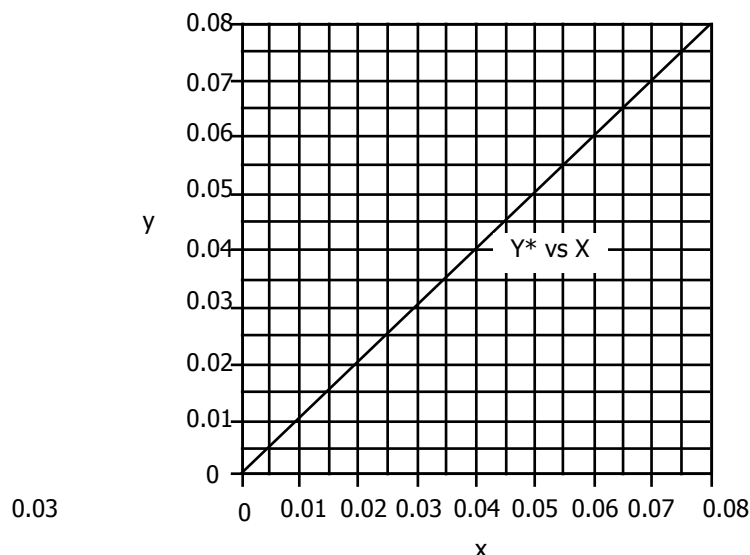

- (A) 12 (B) 10 (C) 8 (D) 6
52. A well-stirred reaction vessel is operated as a semi-batch reactor in which it is proposed to conduct a liquid phase first order reaction of the type  $A \rightarrow B$ . The reactor is fed with the reactant  $A$  at a constant rate of 1 liter/min having feed concentration equal to 1 mol/liter. The reactor is initially empty. Given  $k = 1 \text{ min}^{-1}$ , the conversion of reactant  $A$  based on moles of  $A$  fed at  $t = 2 \text{ min}$  is  
 (A) 0.136 (B) 0.43 (C) 0.57 (D) 0.864
53. A liquid phase exothermic first order reaction is being conducted in a batch reactor under isothermal conditions by removing heat generated in the reactor with the help of cooling water. The cooling water flows at a very high rate through a coil immersed in the reactor such that there is negligible rise in its temperature from inlet to outlet of the coil. If the rate constant is given as  $k$ , heat of reaction ( $-\Delta H$ ), volume of the reactor,  $V$ , initial concentration as  $C_{AO}$ , overall heat transfer coefficient,  $U$ , heat transfer area of the coil is equal to  $A$ , the required cooling water inlet temperature,  $T_{ci}$  is given by the following equation :

(A)  $T_{ci} = T - \frac{(-\Delta H)VkC_{AO}}{UA}$  (B)  $T_{ci} = T - \frac{(-\Delta H)VkC_{AO}e^{-kt}}{UA}$

(C)  $T_{ci} = T - \frac{(-\Delta H)VkC_{AO}e^{-kt}}{UA t}$  (D)  $T_{ci} = T - \frac{(-\Delta H)VkC_{AO}}{UA t}$

54. The following liquid phase reaction is taking place in an isothermal CSTR

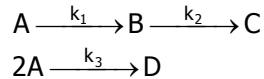

Reaction mechanism is same as the stoichiometry given above. Given  $k_1 = 1 \text{ min}^{-1}$ ;  $k_2 = 1 \text{ min}^{-1}$ ;  $k_3 = 0.5 \text{ lit}/(\text{mol})(\text{min})$ ;  $C_{A0} = 10 \text{ mol/litre}$ ,  $C_{B0} = 0 \text{ mol/litre}$  and  $C_B = 10 \text{ mol/litre}$ , the solution for  $F/V$  (flow rate/reactor volume in  $\text{min}^{-1}$ ) yields

- (A) 6.7 (B) 6 and 0.5 (C) 2 and 4/3 (D) 8

55. A pulse of concentrated KCl solution is introduced as tracer into the fluid entering a reaction vessel having volume equal to  $1 \text{ m}^3$  and flow rate equal to  $1 \text{ m}^3/\text{min}$ . The concentration of tracer measured in the fluid leaving the vessel is shown in the figure given below. The flow model parameters that fit the measured RTD in terms of one or all of the following mixing elements, namely, volume of plug flow reactor,  $V_{pr}$ , mixed flow volume,  $V_m$ , and dead space,  $V_d$ , are

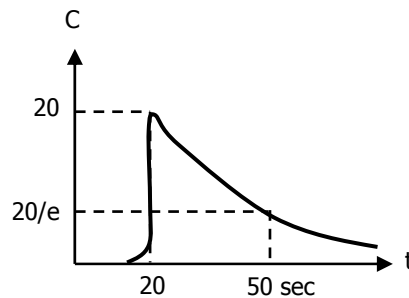

- (A)  $V_p = 1/6 \text{ m}^3$ ,  $V_m = 1/2 \text{ m}^3$ ,  $V_d = 1/3 \text{ m}^3$   
 (B)  $V_p = V_m = V_d = 1/3 \text{ m}^3$   
 (C)  $V_p = 1/3 \text{ m}^3$ ,  $V_m = 1/2 \text{ m}^3$ ,  $V_d = 1/6 \text{ m}^3$   
 (D)  $V_m = 5/6 \text{ m}^3$ ,  $V_d = 1/6 \text{ m}^3$

56. The first order reaction of  $A$  to  $R$  is run in an experimental mixed flow reactor. Find the role played by pore diffusion in the run given below.  $C_{A0}$  is 100 and  $W$  is fixed. Agitation rate was found to have no effect on conversion.

$d_p$	$F_{A0}$	$X_A$
4	2	0.8
6	4	0.4

- (A) strong pore diffusion control  
 (B) diffusion free  
 (C) intermediate role by pore diffusion  
 (D) external mass transfer

57. A packed bed reactor converts  $A$  to  $R$  by first order reaction with 9 mm pellets in strong pore diffusion regime to 63.2% level. If 18 mm pellets are used what is the conversion.

- (A) 0.39 (B) 0.61 (C) 0.632 (D) 0.865

58. The following rate-concentration data are calculated from experiment. Find the activation energy temperature ( $E/R$ ) of the first order reaction.

$d_p$	$C_A$	$-r_A$	$T$
1	20	1	480
2	40	2	480
2	40	3	500

- (A) 2432.8 (B) 4865.6 (C) 9731.2 (D) 13183.3

59. Determine the level of  $C_{AO}$  (high, low, intermediate), temperature profile (high, low, increasing, decreasing), which will favor the formation of the desired product indicated in the reaction scheme given below.

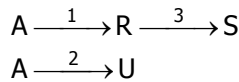

$n_1$	$E_1$	$n_2$	$E_2$	$n_3$	$E_3$
2	25	1	35	3	45

- (A) High  $C_{AO}$ , increasing  $T$ , plug flow reactor  
 (B) Low  $C_{AO}$ , increasing  $T$ , plug flow reactor  
 (C) High  $C_{AO}$ , decreasing  $T$ , mixed flow reactor  
 (D) High  $C_{AO}$ , decreasing  $T$ , plug flow reactor

60. The dynamic model for a mixing tank open to atmosphere at its top as shown below is to be written. The objective of mixing is to cool the hot water stream entering the tank at a flow rate  $q_2$  and feed temperature of  $T_s$  with a cold water food stream entering the tank at a flow rate  $q_1$  and feed temperature of  $T_o$ . A water stream is drawn from the tank bottom at a flow rate of  $q_4$  by a pump and the level in the tank is proposed to be controlled by drawing another water stream at a flow rate  $q_3$ . Neglect evaporation and other heat losses from the tank.

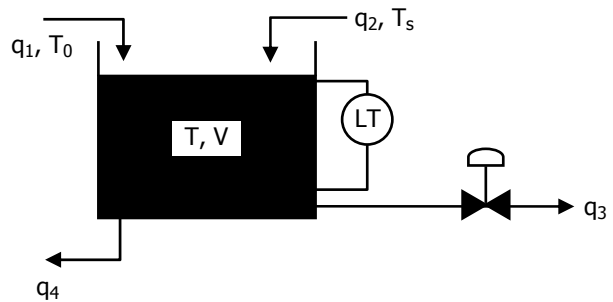

- (A)  $\frac{dV}{dt} = q_1 + q_2 - q_3$ ,  $V \frac{dT}{dt} = q_1 T_o + q_2 T_s - q_3 T$   
 (B)  $\frac{dV}{dt} = q_1 - q_4$ ,  $\frac{d(VT)}{dt} = q_1 T_s - q_4 T$   
 (C)  $\frac{dV}{dt} = q_1 + q_2 - q_4$ ,  $\frac{d(VT)}{dt} = q_1 T_o + q_2 T_s - q_4 T$   
 (D)  $\frac{dV}{dt} = q_1 + q_2 - q_3 - q_4$ ,  $V \frac{dT}{dt} = q_1 (T_o - T) + q_2 (T_s - T)$

61. Match the transfer functions with the responses to a unit step input shown in the figure.

i.  $\frac{-2.5(-4s + 1)}{4s^2 + 4s + 1}$

ii.  $\frac{-2e^{-10s}}{10s + 1}$

iii.  $\frac{-5}{-20s + 1}$

iv.  $\frac{-0.1}{s}$

v.  $\frac{4s + 3}{2s + 1}$

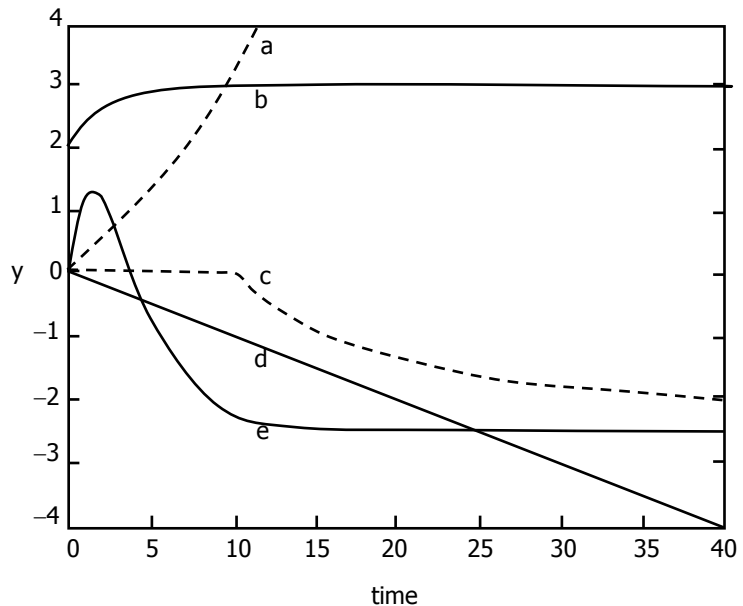

- (A) i-e, ii-c, iii-a, iv-d, v-b  
 (B) i-a, ii-b, iii-c, iv-d, v-e  
 (C) i-b, ii-a, iii-c, iv-e, v-d  
 (D) i-e, ii-a, iii-c, iv-b, v-d

62. Consider the following instrumentation diagram for a chemical reactor.  $C_{sp}$  represents a concentration set point.

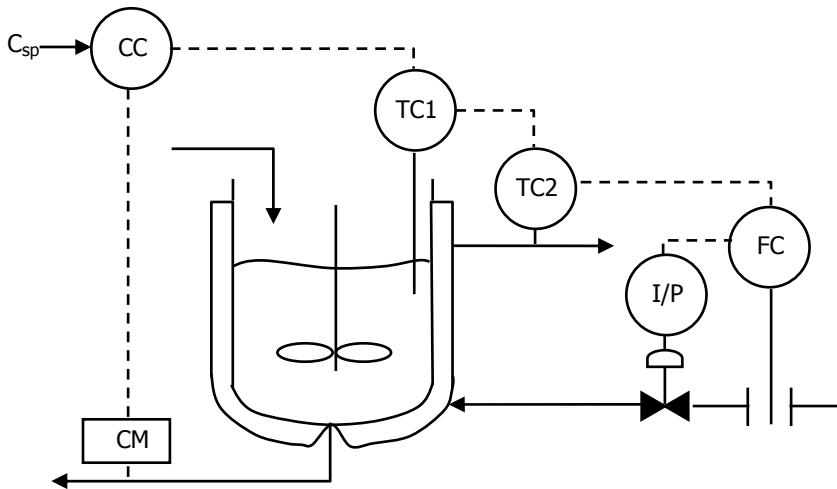

Match the items in group 1 with the corresponding items given in column B.

**Column A**

- P) control strategy
- Q) primary control variable
- R) slowest controller
- S) fastest controller

**Column B**

- 1) feed forward control
- 2) cascade control
- 3) concentration in the reactor
- 4) reactor temperature
- 5) jacket temperature
- 6) concentration controller
- 7) reactor temperature controller
- 8) jacket temperature controller
- 9) flow controller
- 10) selective control

- (A) P-2, Q-3, R-6, S-9
- (C) P-10, Q-7, R-9, S-6

- (B) P-1, Q-4, R-8, S-7
- (D) P-1, Q-8, R-5, S-9

63. The first two rows of Routh's tabulation of a third order equation are

$$\begin{array}{ccc} s^3 & 2 & 2 \\ s^3 & 4 & 4 \end{array}$$

Select the correct answer from the following choices:

- (A) The equation has one root in the right half s-plane
- (B) The equation has two roots on the j axis at  $s = j$  and  $s = -j$ . The third root is in the left half plane.
- (C) The equation has two roots on the j axis at  $s = 2j$  and  $s = -2j$ . The third root is in the left half plane.
- (D) The equation has two roots on the j axis at  $s = 2j$  and  $s = -2j$ . The third root is in the right half plane.

64. Given the following statements listed from P to T, select the correct combination of TRUE statements from the choices that follow this list.

- P) Plate columns are preferred when the operation involves liquids containing suspended solids.
- Q) Packed towers are preferred if the liquids have a large foaming tendency.
- R) The pressure drop through packed towers is more than the pressure drop through plate columns designed for the same duty.
- S) Packed columns are preferred when large temperature changes are involved in distillation operations.
- T) Packed towers are cheaper than plate towers if highly corrosive fluids must be handled.

- (A) T, S, P
- (B) P, Q, T
- (C) S, R, T
- (D) R, Q, S

- 
65. A pump has an installed cost of Rs. 40,000 and a 10-year estimated life. The salvage value of the pump is zero at the end of 10 years. The pump value (in rupees) after depreciation by the double declining balance method, at the end of 6 years is  
(A) 4295 (B) 10486 (C) 21257 (D) 37600
66. In a double pipe heat exchanger the ID and OD of the inner pipe are 4 cm and 5 cm respectively. The ID of the outer pipe is 10 cm with a wall thickness of 1 cm. Then the equivalent diameters (in cm) of the annulus for heat transfer and pressure drop respectively are  
(A) 15, 5 (B) 21, 6 (C) 6, 19 (D) 15, 21
67. Match the chemicals in Group 1 with their function in Group 2.  
**Group 1**  
P. styrene  
Q. tert-dodecyl mercaptan  
R. potassium pyrophosphate  
**Group 2**  
1) buffer  
2) catalyst  
3) modifier  
4) monomer  
(A) P-1, Q-4, R-4, (B) P-4, Q-1, R-2,  
(C) P-4, Q-1, R-3, (D) P-4, Q-3, R-1,
68. Match the product in Group 1 with its application in the industries of Group 2  
**Group 1**  
P. lithium stearate  
Q. magnesium stearate  
R. aluminium sulphate  
**Group 2**  
1) cosmetics  
2) paper  
3) dry cleaning  
(A) P-2, Q-3, R-1, (B) P-3, Q-4, R-2,  
(C) P-4, Q-2, R-3, (D) P-4, Q-1, R-2,
69. Match the synthetic fibres in Group 1 with their classification in Group 2.  
**Group 1**  
P. Rayon  
Q. Orlon  
R. Dacron  
**Group 2**  
1) polyamide  
2) polyester  
3) cellulose  
(A) P-2, Q-3, R-1, (B) P-3, Q-4, R-2,  
(C) P-3, Q-1, R-3, (D) P-3, Q-3, R-4,
70. Match the Petrochemical derivative in Group 1 with the raw materials in Group 2.  
**Group 1**  
P. acrylonitrile  
Q. ammonia  
R. dodecene  
**Group 2**  
1) methane  
2) ethane  
3) ethylene  
4) propylene  
(A) P-1, Q-2, R-1, (B) P-2, Q-1, R-2,  
(C) P-3, Q-4, R-3, (D) P-4, Q-1, R-4,

**COMMON DATA QUESTIONS**

**Common Data for Questions 71, 72, 73:**

71. A cascade control system for pressure control is shown in the figure given below. The pressure transmitter has a range of 0 to 6 bar (g) and the flow transmitter range is 0 to 81 nm<sup>3</sup>/hr. The normal flow rate through the valve is 32.4 nm<sup>3</sup>/hr corresponding to the value of set point for pressure = 1 bar (g) and to give the flow, the valve must be 40% opened. The control valve has linear characteristics and is fail-open (air to close). Error, set point and control variable are expressed in percentage transmitter output (% TO). Proportional gain is expressed in the units of % controller output (CO/% TO).

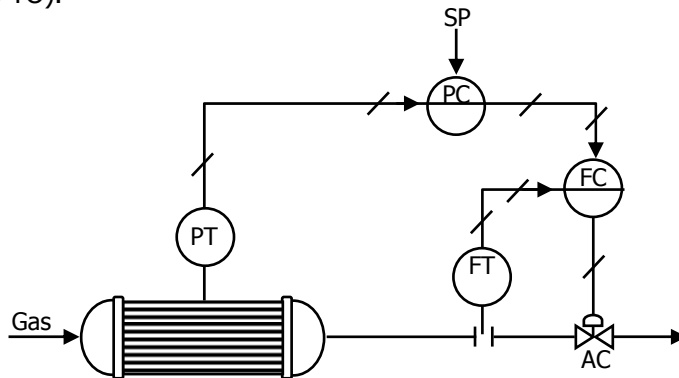

The types of action for the two controllers are

- (A) direct acting for the pressure control and direct acting for the flow control
  - (B) indirect acting for the pressure control and indirect acting for the flow control
  - (C) direct acting for the pressure control and indirect acting for the flow control
  - (D) indirect acting for the pressure control and direct acting for the flow control
72. The bias values for the two controllers, so that no offset occurs in either controller are
- (A) Pressure controller: 40%; Flow controller: 60%
  - (B) Pressure controller: 33%; Flow controller: 67%
  - (C) Pressure controller: 67%; Flow controller: 33%
  - (D) Pressure controller: 60%; Flow controller: 40%
73. Given that the actual tank pressure is 4 bar(g) and a proportional controller is employed for pressure control, the proportional band setting of the pressure controller required to obtain a set point to the flow controller equal to 54 nm<sup>3</sup>/hr is
- (A) 50%                      (B) 100%                      (C) 150%                      (D) 187%

**Common Data for Questions 74, 75:**

74. The following liquid phase reaction is taking place in an isothermal batch reactor

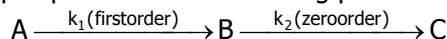

Feed concentration = 1 mol/litre

The time at which the concentration of B will reach its maximum value is given by

- (A)  $t = \frac{1}{k_1} \ln\left(\frac{k_1}{k_2}\right)$                       (B)  $t = \frac{1}{k_2 - k_1} \ln\left(\frac{k_2}{k_1}\right)$
- (C)  $t = \frac{1}{k_2} \ln\left(\frac{k_2}{k_1}\right)$                       (D)  $t = \frac{1}{k_2} \ln\left(\frac{k_1}{k_2}\right)$

75. The time at which the concentration of B will become zero is given by the following equation:
- (A)  $(1 - e^{-k_1 t}) = k_2 t$  (B)  $t = \infty$   
 (C)  $t = \frac{1}{k^2}$  (D)  $t = \frac{1}{k_1}$

**Linked Answer Questions: Q. 76 to Q. 85 carry two marks each.**

**Statement for Linked Answer Questions 76 & 77:**

76. A methanol-water vapor liquid system is at equilibrium at 60°C and 60 kPa. The mole fraction of methanol in liquid is 0.5 and in vapor is 0.8. Vapor pressure of methanol and water at 60°C are 85 kPa and 20 kPa respectively. Assuming vapor phase to be an ideal gas mixture, what is the activity coefficient of water in the liquid phase?
- (A) 0.3 (B) 1.2 (C) 1.6 (D) 7.5
77. What is the excess Gibbs free energy ( $g^E$ , in J/mol) of the liquid mixture?
- (A) 9.7 (B) 388 (C) 422 (D) 3227

**Statement for Linked Answer Questions 78 & 79:**

78. A simplified flowsheet is shown in the figure for production of ethanol from ethylene. The conversion of ethylene in the reactor is 30% and the scrubber following the reactor completely separates ethylene (as top stream) and ethanol and water as bottoms. The last (distillation) column gives an ethanol-water azeotrope (90 mol% ethanol) as the final product and water as waste. The recycle to purge ratio is 34.

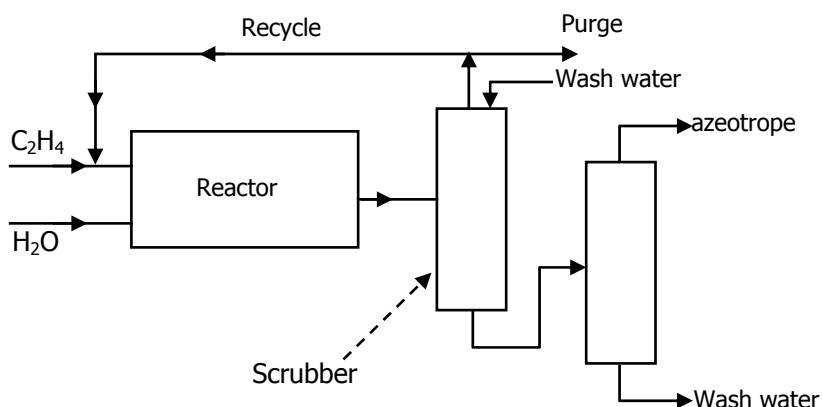

The reaction is:  $C_2H_4 (g) + H_2O (g) \rightarrow C_2H_5OH (g)$

For an azeotrope product rate of 500 mols/hr, the recycle gas flowrate in mols/hr is

(A) 30 (B) 420 (C) 1020 (D) 1500

79. For the same process, if fresh  $H_2O$  feed to the reactor is 600 mol/hr and wash water for scrubbing is 20% of the condensables coming out of the reactor, the water flowrate in mols/hr from the distillation column as bottoms is
- (A) 170 (B) 220 (C) 270 (D) 430



---

**Statement for Linked Answer Questions 80 & 81:**

80. 44 kg of  $C_3H_8$  is burnt with 1160 kg of air (Mol. Wt. = 29) to produce 88 kg of  $CO_2$  and 14 kg of CO  
 $C_3H_8 + 5 O_2 = 3 CO_2 + 4 H_2O$   
What is the percent excess air used?  
(A) 55 (B) 60 (C) 65 (D) 68
81. What is the % carbon burnt?  
(A) 63.3 (B) 73.3 (C) 83.3 (D) 93.3

**Statement for Linked Answer Questions 82 & 83:**

82. A perfectly insulated cylinder of volume  $0.6 m^3$  is initially divided into two parts by a thin, frictionless piston, as shown in the figure. The smaller part of volume  $0.2 m^3$  has ideal gas at 6 bar pressure and  $100^\circ C$ . The other part is evacuated.

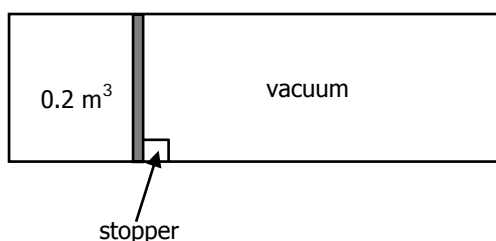

- At certain instant of time  $t$ , the stopper is removed and the piston moves out freely to the other end. The final temperature is  
(A)  $-140^\circ C$  (B)  $-33^\circ C$  (C)  $33^\circ C$  (D)  $100^\circ C$
83. The cylinder insulation is now removed and the piston is pushed back to restore the system to its initial state. If this is to be achieved only by doing work on the system (no heat addition, only heat removal allowed), what is the minimum work required?  
(A) 3.4 kJ (B) 107 kJ (C) 132 kJ (D) 240 kJ

**Statement for Linked Answer Questions 84 & 85:**

84. A fluidized bed (0.5m dia, 0.5m high) of spherical particles (diameter =  $2000 \mu m$ , specific gravity = 2.5) uses water as the medium. The porosity of the bed is 0.4. The Ergun eqn. For the system is  
 $\Delta P/L = 4 \times 10^5 U_{mf} + 1 \times 10^7 U_{mf}^2$   
(SI unit,  $U_{mf}$  in m/s).  
 $\Delta P/L$  (SI unit) at minimum fluidization condition is  
( $g = 9.8 m/sec^2$ ).  
(A) 900 (B) 8820 (C) 12400 (D) 17640
85. The minimum fluidization velocity (mm/sec) is  
(A) 12.8 (B) 15.8 (C) 24.8 (D) 28.8